

MonoRail Showcase Kit

Total Solution for Showcase

Convenient Pole System for Multi-use



- The showcase kit convenient for all
- Showcase kit using MonoRail system
- Plug & Play display system
- Adjustable length
- Slide LED fixtures along power track
- Available in silver or black
- To be used with constant voltage DC 24V driver



Slide LED fixtures along MNR-Rail



Adjustable pole length



Installation

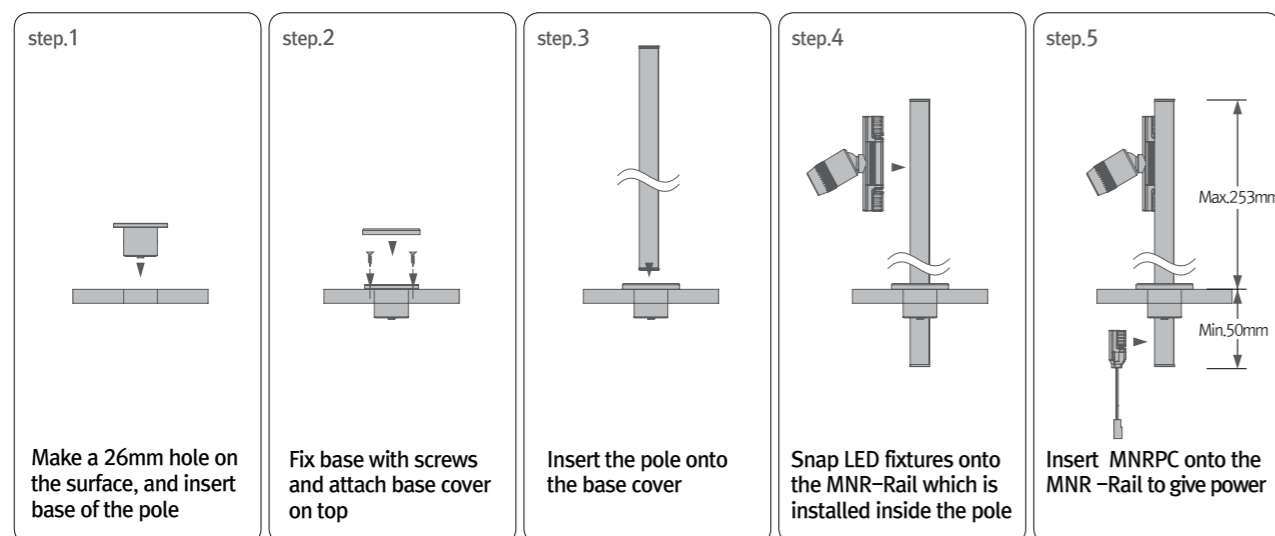

Dimension

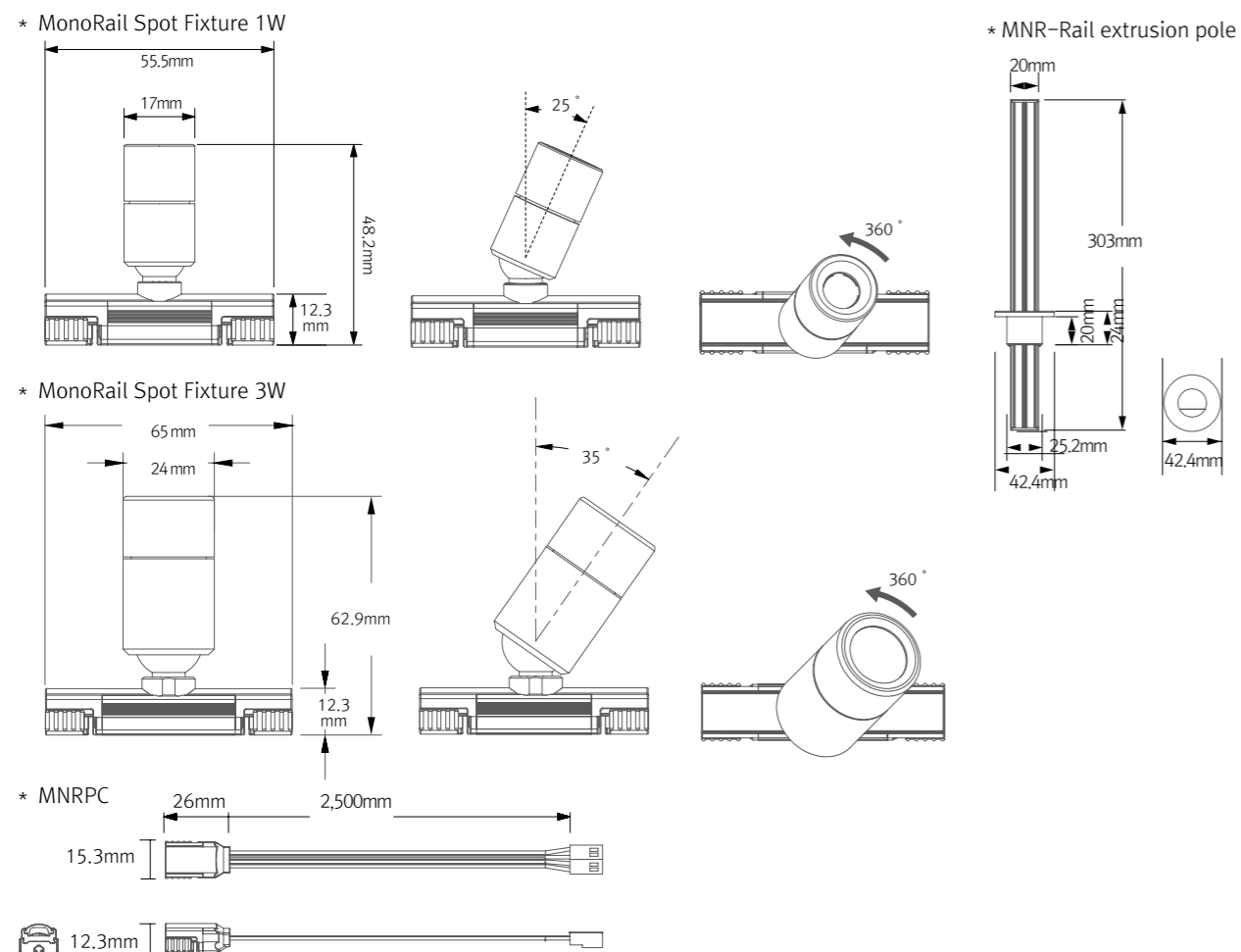

Required Accessories

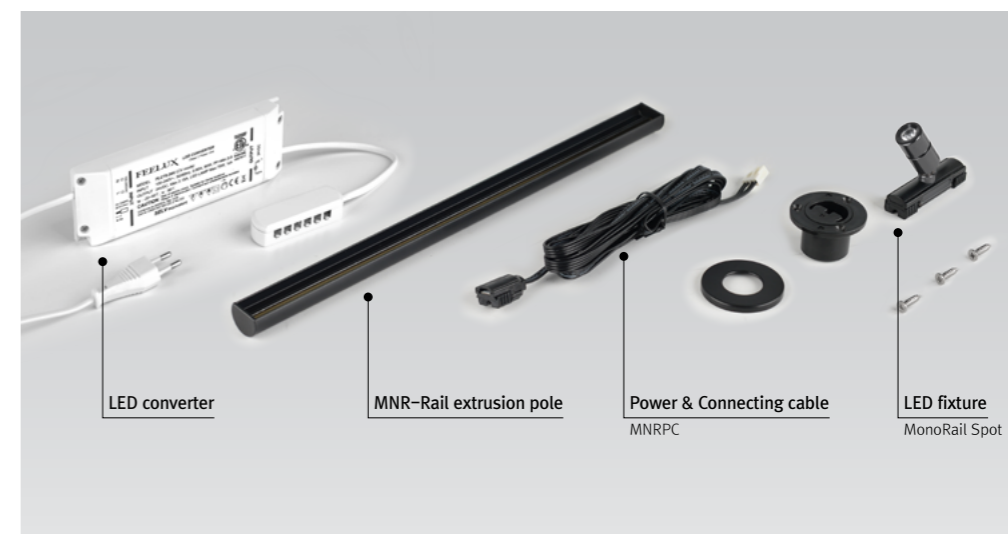

Accessories

Ⓐ MNR-Rail extrusion pole (300mm)

	Silver	Black
	MNR-EXP-SV	MNR-EXP-BK

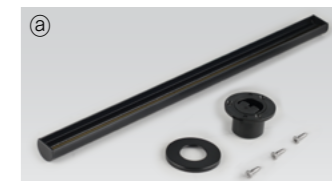

Ⓑ MonoRail Spot

Beam angle	Silver	Black
15°	MRS1 40K-24V-SV-15	MRS1 40K-24V-BK-15
30°	MRS1 40K-24V-SV-30	MRS1 40K-24V-BK-30



Ⓒ MonoRail Spot HO

Beam angle	Silver	Black
25°	MRS3 40K-24V-SV-25	MRS3 40K-24V-BK-25
45°	MRS3 40K-24V-SV-45	MRS3 40K-24V-BK-45
60°	MRS3 40K-24V-SV-60	MRS3 40K-24V-BK-60



Ⓓ Power supply cable to the MNR-Rail : MNRPC (2500mm)

120W in one row (w/ terminal block)
180W in one row (w/o terminal block)



Ⓔ LED Driver with 12way distributor, with power cord (1800mm)

Part NO	FLC15-24V/T	FLC30-24V/T	FLC75-24V/T
Capacity	24V/15W	24V/30W	24V/75W

